

EBP60

Trailer-Mounted Concrete Pump

Titan



Titan Makina Ltd. Şti.

1160. Sok. No:9 Ostim 06370 Ankara / Turkey

Phone : +90 312 354 9977 • Fax : +90 312 385 5611 • E-mail : titan@titanltd.com.tr • Web : www.titanltd.com.tr

EBP60

Trailer-Mounted Concrete Pump

Titan

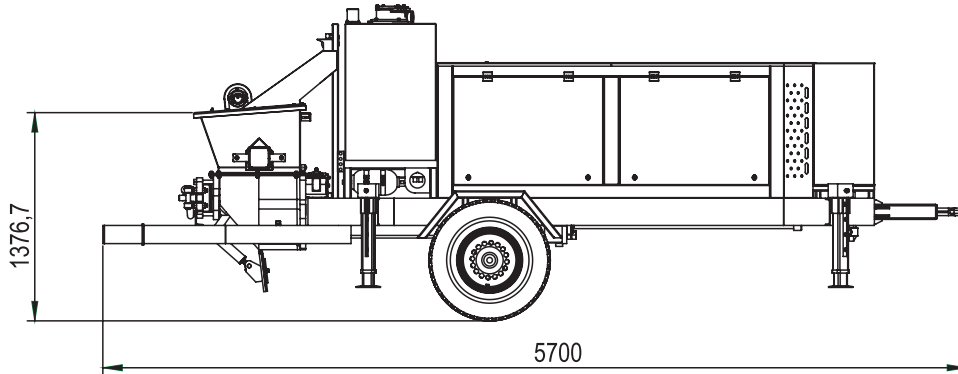

TECHNICAL SPECIFICATIONS

CONCRETE PUMP

Make / Model:	Titan hydraulically driven double piston pump
Max. Capacity:	55 m ³ /h (theoretical)
Max. Concrete Pressure:	60 bar
Max. Hydraulic Pressure:	240 bar
Power:	Electric driven - 90 kW at 400 V - 50 Hz
Concrete Cylinder:	180 x 1.250 mm
Outlet Diameter:	5"

HOPPER

Hopper Capacity:	250 l
Filling Height:	1380 mm
Working Light:	55 W halogen
Vibrator:	Hydraulically driven
Bottom Shutter:	Hydraulically driven
Hopper Agitator:	Hydraulically driven

WATER PUMP and CLEANING SYSTEM

Water Pump:	Hydraulically driven
Pressure:	25 bar
Flow Rate:	16 l/min
Hose Length:	8 m
Water Tank:	190 l

DIMENSIONS & WEIGHT

Dry Weight:	3.600 kg
Length:	5.700 mm
Width:	1.800 mm
Height:	2.080 mm

MISCELLANEOUS

Tyres:	7.50 - 16
	Basic tool set
	Front and rear tow bar
	Manual stabiliser

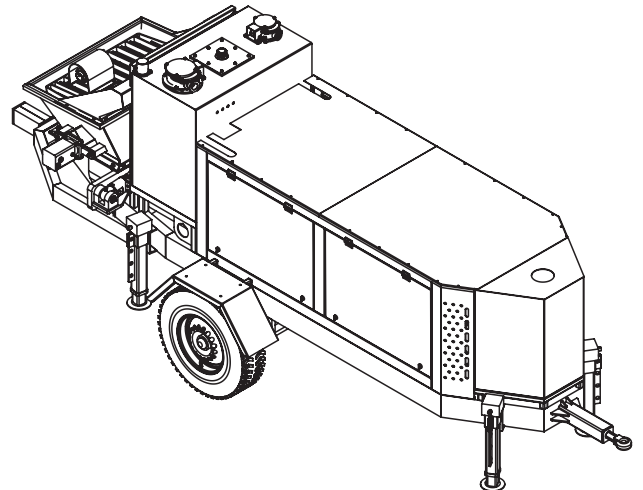
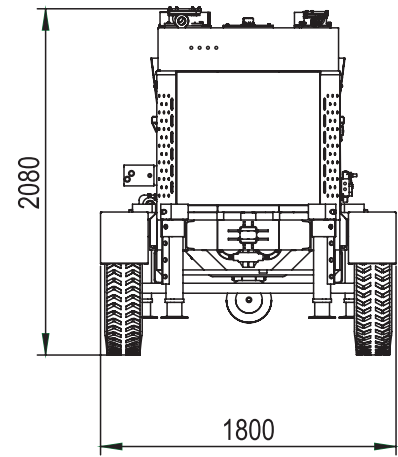

Titan Makina Ltd. Şti.

1160. Sok. No:9 Ostim 06370 Ankara / Turkey

Phone : +90 312 354 9977 • Fax : +90 312 385 5611 • E-mail : titan@titanltd.com.tr • Web : www.titanltd.com.tr