

BPT24

PERSONNEL CARRIER



ROPS & FOPS level 2 certified, closed 24-person cabin



ROPS & FOPS level 2 certified closed 2-person cabin



Rear view camera and LCD screen in operator cabin

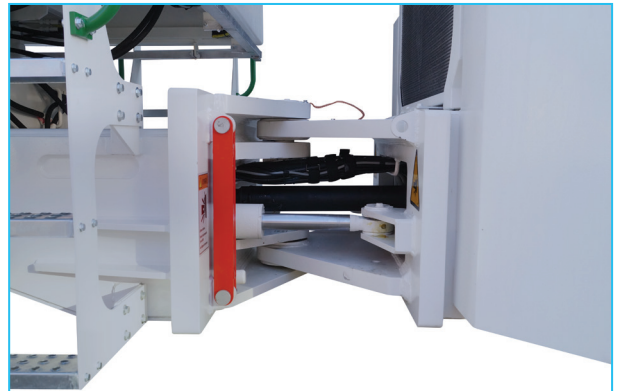

High strength articulated chassis

DIMENSIONS & PERFORMANCE

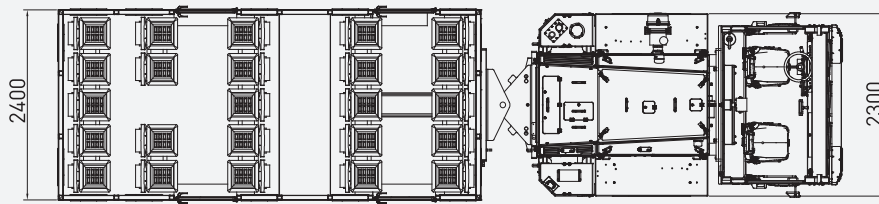
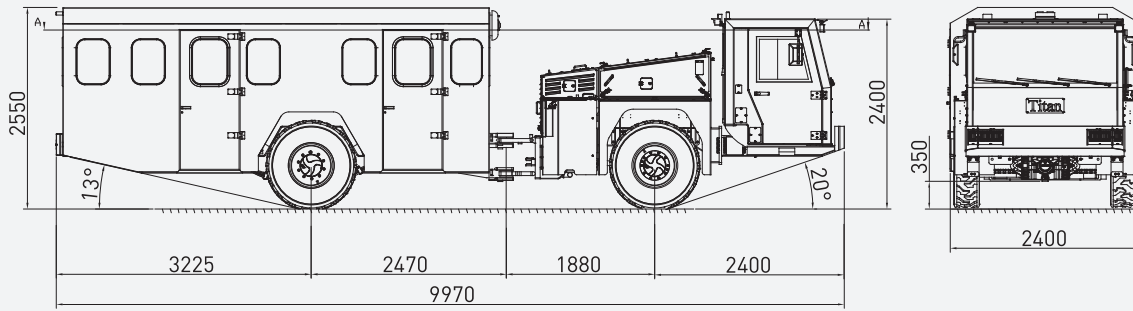

SECTION A-A

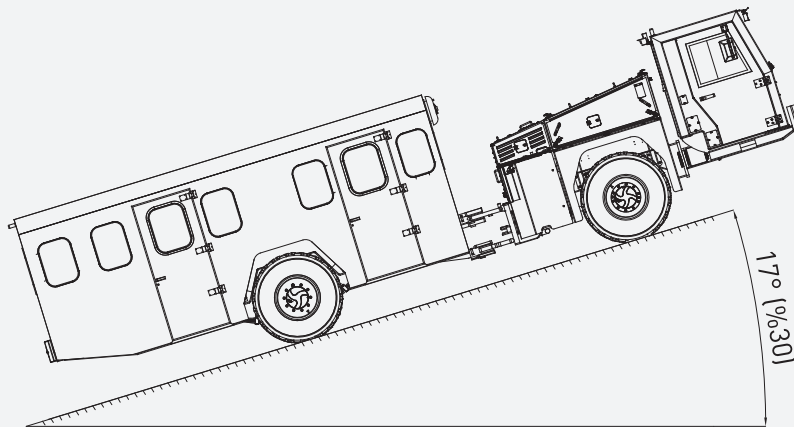

TURNING RADIUS

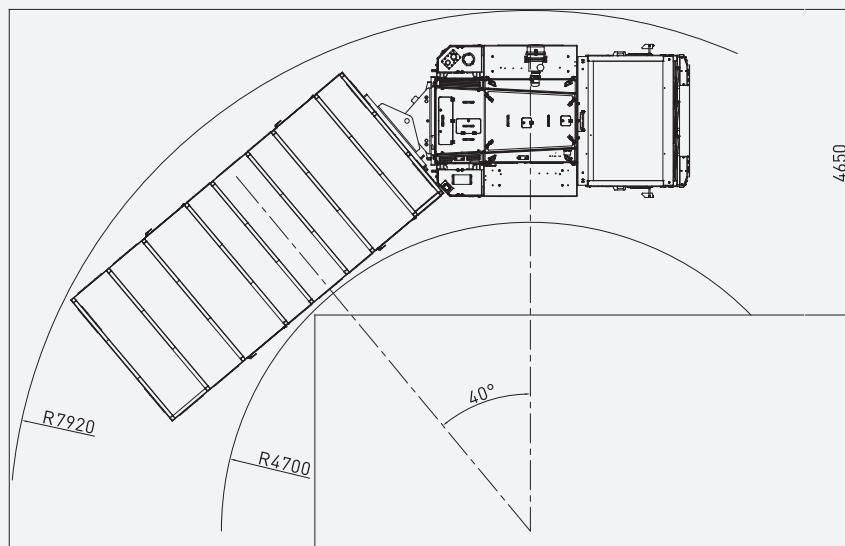

TECHNICAL SPECIFICATIONS

DIESEL ENGINE		ELECTRIC SYSTEM	
Make / Model:	Deutz TCD 2013 L4 2V	Battery:	24 V – 2 x 105 Ah
Max. Power:	129 kW at 2300 rpm	Protection:	IP65
Max. Torque:	670 Nm at 1600 rpm	Lights:	6 x 1500 Lumen Led in front of the operator cabin
Engine Emission:	EU Stage 3A / US EPA Tier 3		2 x 1500 Lumen Led behind of the operator cabin
Diesel Tank:	140 l		2 x 1500 Lumen Led at bumper
	With Catalytic Converter and Silencer		Turn signals and taillights
TRANSMISSION		Box Type:	Stainless steel
Make / Model:	Dana Spicer T24000	Beacon Lamp:	Amber color
	Powershift	TITAN CLOSED OPERATOR CABIN	
	Automatic 3-speed forward and reverse	<ul style="list-style-type: none"> • Closed 2-person cabin • ROPS & FOPS level 2 certified (EN ISO 3471:2008 / EN ISO 3449:2008) • Mechanical suspension with manual tilt, weight, height adjustable, "T" shaped seat with 3-point seat belt • Cabin heater • Rear view camera and LCD screen in operator cabin • Levers and indicators for all driving controls • In-Cabin radio output and location (12V) • Cabin lighting • Heated wing mirrors • Document box under the seat • Equipment box 	
	Four-wheel drive	DIMENSIONS & WEIGHT	
AXLES & TYRES		Weight:	13650 kg (Approximately)
Make / Model:	Dana Spicer 113	Length:	9970 mm
Type:	Planetary	Width:	2400 mm
Front:	+/- 8° Oscillating	Height:	2550 mm
Rear:	Spring leaf + shock absorber	Inner Turning Radius:	4700 mm
Tyres:	12.00 – 20	Outer Turning Radius:	7920 mm
PERFORMANCE		MISCELLANEOUS	
Max. Gradient:	30%	<ul style="list-style-type: none"> • Warning plates and decals • Tool box • 2x4 kg portable fire extinguisher (1 in operator cabin) • 2 pcs Wheel chocks • Front towbar • Back-up alarm and light • Battery isolator switch 	
Max. Speed:	24.5 km/h		
Max. Tractive Effort:	122 kN		
STEERING			
	Articulation, +/- 40°		
	Orbitrol Type		
BRAKING SYSTEM			
Service Brake:	Hydraulically powered two-circuit oil immersed multidisc brakes in both axles		
Safety/Parking Brake:	Spring applied hydraulic released SAHR		
	Fail safe		
CHASSIS			
Type:	Articulated, high strength steel		
HYDRAULIC SYSTEM			
Pump Type:	Fixed and variable displacement		
Max. Pressure:	210 bar		
Flow Rate:	120 l/min at 2300 rpm		
Hydraulic Oil Tank:	140 l		
Return Oil Filter:	25 µm		
	Oil level, filtration and temperature indicators		

TITAN CLOSED PERSONNEL CABIN

- Closed 24-person cabin
- ROPS & FOPS level 2 certified
(EN ISO 3471:2008 / EN ISO 3449:2008)
- Height adjustable ergonomic seat with 2 points seat belt
- Cabin heater
- 4 Outward opening doors (Sliding windows on doors)
- Mica glass windows
- Ventilation in the cabin
- Amber color beacon on cabin
- Cabin lighting
- Intercom between operator cabin and personnel cabin
- 2x4 kg portable fire extinguisher
- Emergency exit windows on doors

OTHER

- Centralized greasing system

OPTIONS

- Automatic centralized lubrication system
- Electrical outlet in the cabin 220 Volt - 150 Watt
- Air-conditioner (Heating and Cooling) in the cabin
- Manual activated fire extinguishing system
- Automatic and Manual activated fire extinguishing system (Linear wired)
- 24 V emergency steering
- Diesel particulate filter - DPF
- EU Stage 5 diesel engine
- Additional side view camera
- Spare wheel