

BKPT7

MATERIAL TRANSPORTER



ROPS & FOPS level 2 certified closed 4-person personnel cabin



Manual opening / closing awning mechanism on the case

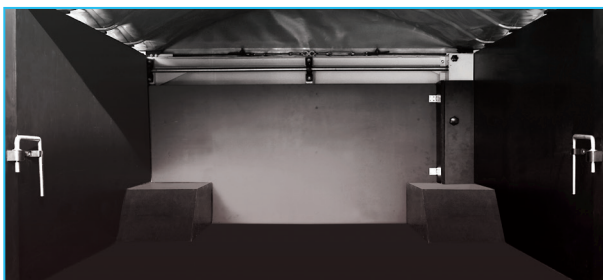

7000 kg carrying capacity pick-up box



ROPS & FOPS level 2 certified closed 2-person cabin



Rear view camera and LCD screen in operator cabin

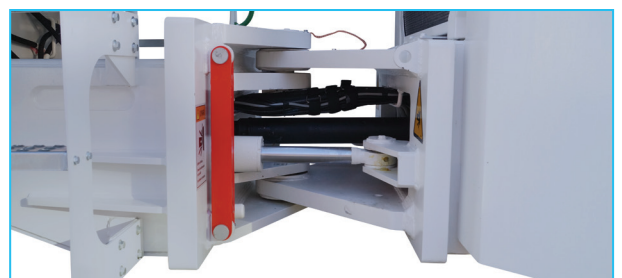

High strength articulated chassis

DIMENSIONS & PERFORMANCE

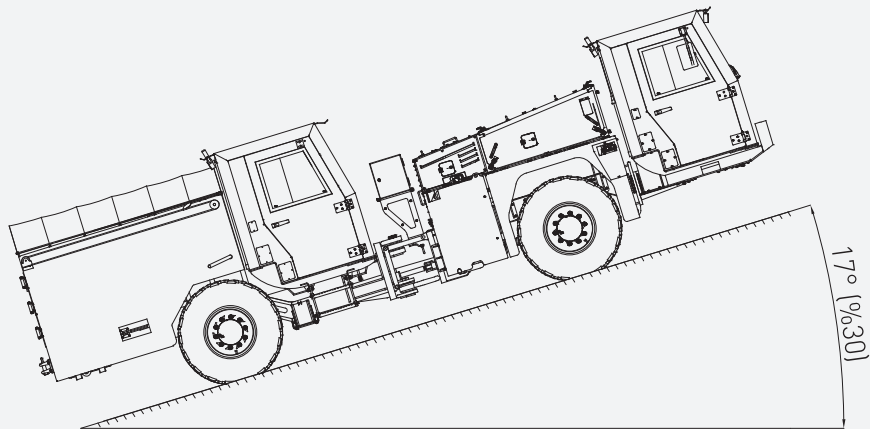
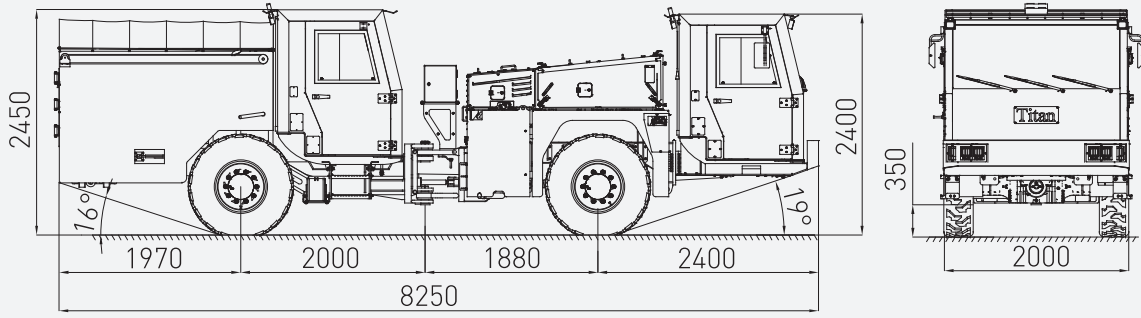

TURNING RADIUS

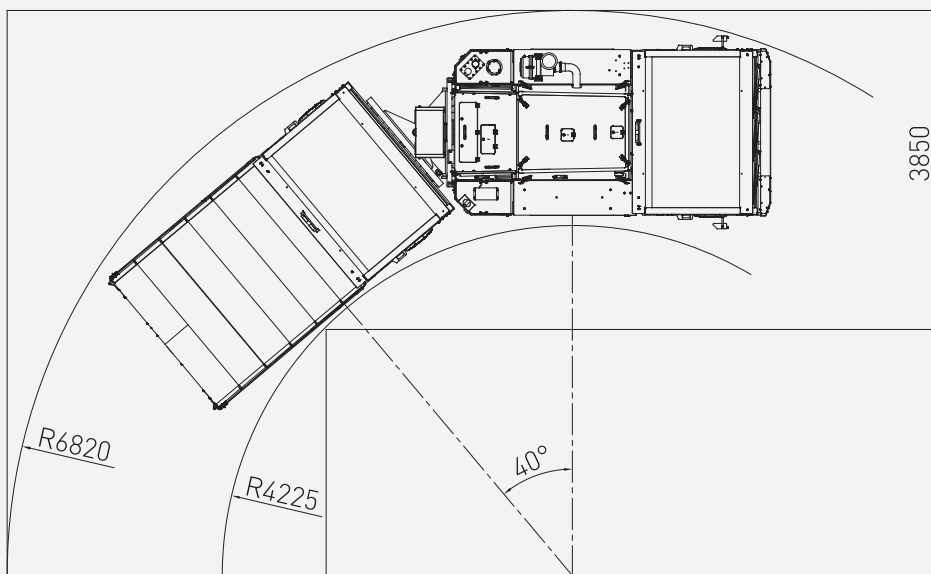

TECHNICAL SPECIFICATIONS

DIESEL ENGINE	
Make / Model:	Deutz TCD 2013 L4 2V
Max. Power:	129 kW at 2300 rpm
Max. Torque:	670 Nm at 1600 rpm
Engine Emission:	EU Stage 3A / US EPA Tier 3
Diesel Tank:	150 l
With Catalytic Converter and Silencer	
TRANSMISSION	
Make / Model:	Dana Spicer T24000
Powershift	
Automatic 3-speed forward and reverse	
Four-wheel drive	
AXLES & TYRES	
Make / Model:	Dana Spicer 113
Type:	Planetary
Front:	+/- 8° Oscillating
Rear:	Rigid
Tyres:	12.00 – 20
PERFORMANCE	
Max. Gradient:	30%
Max. Speed:	24.5 km/h
Max. Tractive Effort:	122 kN
STEERING	
Articulation, +/- 40°	
Orbitrol Type	
BRAKING SYSTEM	
Service Brake:	Hydraulically powered two-circuit oil immersed multidisc brakes in both axles
Safety/Parking Brake:	Spring applied hydraulic released SAHR
Fail safe	
CHASSIS	
Type:	Articulated, high strength steel
HYDRAULIC SYSTEM	
Pump Type:	Variable displacement
Max. Pressure:	210 bar
Flow Rate:	125 l/min at 2300 rpm
Hydraulic Oil Tank:	150 l
Return Oil Filter:	25 µm
Oil level, filtration and temperature indicators	

ELECTRIC SYSTEM	
Battery:	24 V – 2 x 105 Ah
Protection:	IP65
Lights:	6 x 1500 Lumen Led in front of the operator cabin
	2 x 1500 Lumen Led behind the operator cabin
	2 x 1500 Lumen Led behind the personnel cabin
	2 x 1500 Lumen Led at bumper
	Turn signals and taillights
Box Type:	Stainless steel
Beacon Lamp:	Amber color
TITAN CLOSED OPERATOR CABIN	
<ul style="list-style-type: none"> • Closed 2-person cabin • ROPS & FOPS level 2 certified (EN ISO 3471:2008 / EN ISO 3449:2008) • Mechanical suspension with manual tilt, weight, height adjustable, "T" shaped seat with 3-point seat belt • Cabin heater • Rear view camera and LCD screen in operator cabin • Levers and indicators for all driving controls • In-Cabin radio output and location (12V) • Cabin lighting • Heated wing mirrors • Document box under the seat • Equipment box 	
DIMENSIONS & WEIGHT	
Weight:	11450 – 12000 kg*
Length:	8250 mm
Width:	2000 mm
Height:	2450 mm
Inner Turning Radius:	4225 mm
Outer Turning Radius:	6820 mm
*Depends on option	
MISCELLANEOUS	
<ul style="list-style-type: none"> • Warning plates and decals • Tool box • 3 portable fire extinguisher (1 in operator cabin (4 kg), 2 in personnel cabin (2 kg)) • 2 pcs Wheel chocks • Front and rear towbar • Back-up alarm and light • Battery isolator switch 	

TITAN CLOSED PERSONNEL CABIN

- Closed 4-person cabin
- ROPS & FOPS level 2 certified (EN ISO 3471:2008 / EN ISO 3449:2008)
- Height adjustable ergonomic seat with seat belt
- Cabin heater
- Cabin doors on both sides (right-left)
- Hand rails and horn on the ceiling of the cabin
- Cabin floor covered with non-slip material
- Intercom between operator cabin and personnel cabin

PICK-UP BOX

Dimensions: 2320 x 2000 x 980 mm

Max. Carrying Capacity: 7000 kg

Type: Open top for transportation of explosives

Inner Surface: Waterproof wooden lining

Doors: Two doors at rear (for loading & unloading)

Can be fixed when opened

- Plywood upholstered case internal surfaces
- Rear doors can be fixed at 90° and 270°
- Manual opening / closing awning mechanism on the case

DETONATOR BOX

Dimensions: 800 x 500 x 500 mm

Material: Steel box

- Placed over articulation
- Anti-static inner surface
- Lockable covers

OTHER

- Centralized greasing system

OPTIONS

- Automatic centralized lubrication system
- Electrical outlet in the cabin 220 Volt - 150 Watt
- Air-conditioner (Heating and Cooling) in the cabin
- Manual activated fire extinguishing system
- Automatic and manual activated fire extinguishing system (Linear wired)
- 24 V emergency steering
- Diesel particulate filter - DPF
- EU Stage 5 diesel engine
- Additional side view camera
- Spare wheel