

# AC500

ANFO CHARGER TRUCK



2 pcs remote controlled, hydraulically driven ANFO charging hose feeder



2 x 500 l stainless steel ANFO tanks

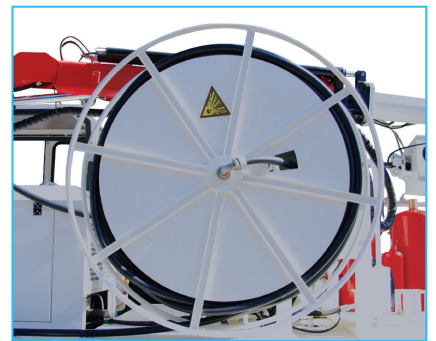

Hydraulically driven ANFO charging hose reel



Cable remote control

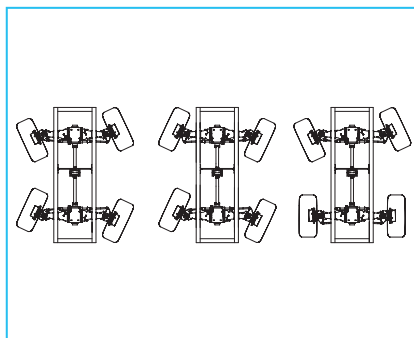

3 steering modes; Four-wheel steering, Front-wheel steering and Crab steering



ROPS and FOPS level 2 certified closed operator cabin with 180° pivoting operator's seat

## DIMENSIONS & PERFORMANCE

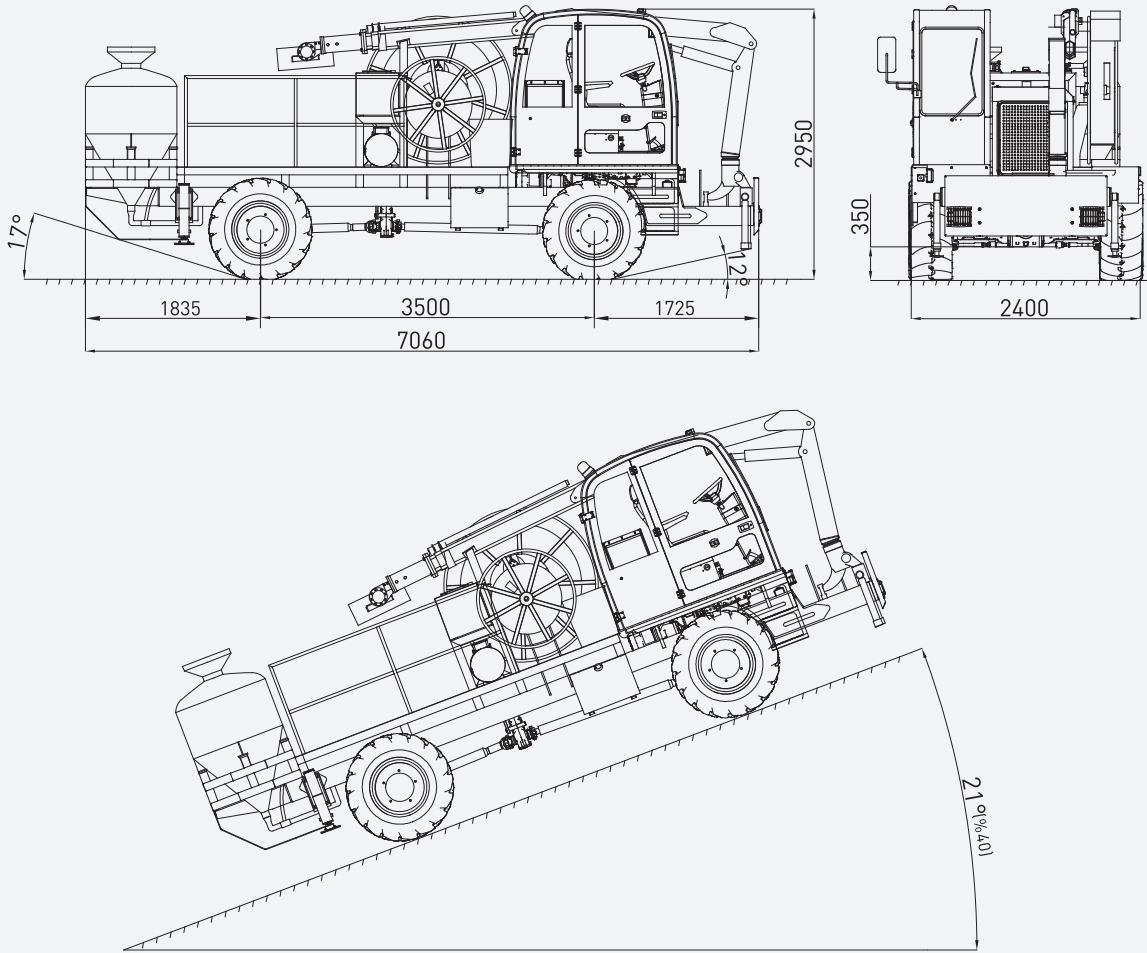

## TURNING RADIUS

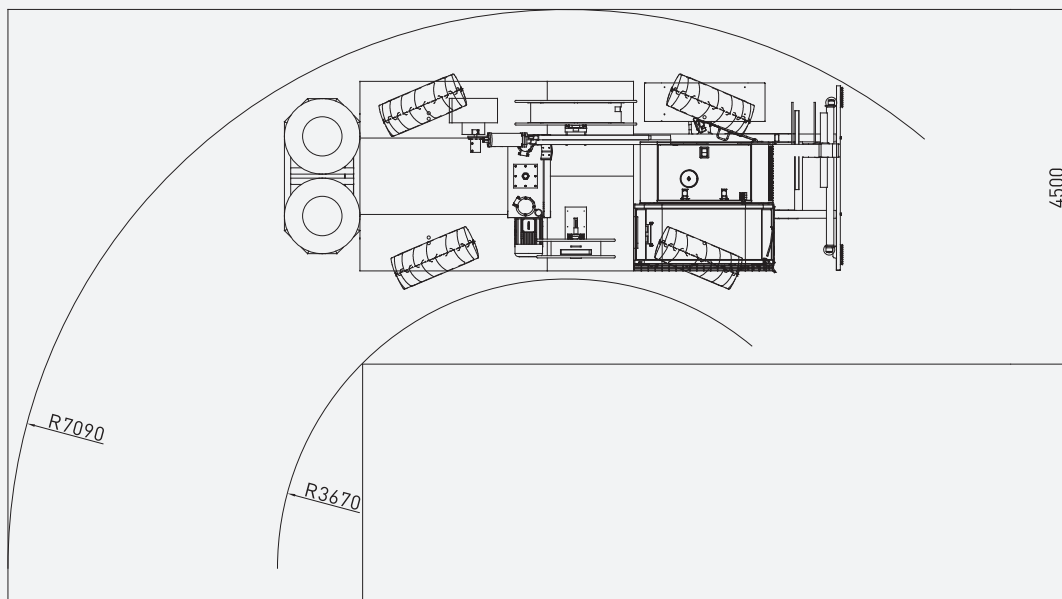

## TECHNICAL SPECIFICATIONS

<b>DIESEL ENGINE</b>	
<b>Make / Model:</b>	JCB Dieselmax 444 TCA-85
<b>Max. Power:</b>	85 kW at 2200 rpm
<b>Max. Torque:</b>	440 Nm at 1300 rpm
<b>Engine Emission:</b>	EU Stage 3A / US EPA Tier 3
<b>Diesel Tank:</b>	140 l
With Catalytic Converter and Silencer	
<b>TRANSMISSION</b>	
<b>Make / Model:</b>	JCB PS760
Powershift	
Automatic and Manual 4-speed forward	
Manual 3-speed reverse	
Four-wheel drive	
<b>AXLES &amp; TYRES</b>	
<b>Make / Model:</b>	JCB SD70
<b>Type:</b>	Planetary
<b>Front Axle:</b>	+/- 8° Oscillating and steerable
<b>Rear Axle:</b>	Rigid and steerable
<b>Tyres:</b>	16.00 / 70-20
<b>PERFORMANCE</b>	
<b>Max. Gradient:</b>	40%
<b>Max. Speed:</b>	24.5 km/h
<b>STEERING</b>	
Four-wheel steering	
Crab steering	
Front-wheel steering	
<b>BRAKING SYSTEM</b>	
<b>Service Brake:</b>	Hydraulically powered two-circuit oil immersed multidisc brakes in both axles
<b>Safety/Parking Brake:</b>	Spring applied hydraulic released SAHR Fail safe
<b>CHASSIS</b>	
<b>Type:</b>	Rigid, high strength steel
<b>Front Stabilisers:</b>	2 pcs, extendible
<b>Rear Stabilisers:</b>	2 pcs, fixed
<b>HYDRAULIC SYSTEM</b>	
<b>Pump Type:</b>	Variable displacement piston and gear pump
<b>Max. Pressure:</b>	210 bar
<b>Flow Rate:</b>	150 l/min at 2200 rpm
<b>Hydraulic Oil Tank:</b>	200 l
<b>Return Oil Filter:</b>	25 µm
Oil level, filtration and temperature indicators	
<b>ELECTRIC SYSTEM</b>	
<b>Battery:</b>	12 V - 150 Ah
<b>Protection:</b>	IP65
<b>Lights:</b>	2 x 1500 Lumen Led at front bumper
2 x 1500 Lumen Led on operator cabin	
1 x 1500 Lumen Led at rear	
1 x 1500 Lumen Led on boom	
Turn signals and taillights	
<b>Beacon Lamp:</b>	Amber color
<b>TITAN CLOSED OPERATOR CABIN</b>	
<ul style="list-style-type: none"> <li>• Closed 1-person cabin</li> <li>• ROPS and FOPS level 2 certified (EN ISO 3471:2008 / EN ISO 3449:2008)</li> <li>• Mechanical suspension with manual tilt, weight, height adjustable, 180° pivotable ergonomic seat with seat belt</li> <li>• Cabin heater</li> <li>• Levers and indicators for all driving controls</li> <li>• In-cabin radio output and location (12V)</li> <li>• Cabin lighting</li> <li>• Heated wing mirrors</li> </ul>	
<b>DIMENSIONS &amp; WEIGHT</b>	
<b>Weight:</b>	8800 kg (Approximately)
<b>Length:</b>	7060 mm
<b>Width:</b>	2400 mm
<b>Height:</b>	2950 mm
<b>Inner Turning Radius:</b>	3670 mm
<b>Outer Turning Radius:</b>	7090 mm
<b>MISCELLANEOUS</b>	
<ul style="list-style-type: none"> <li>• Warning plates and decals</li> <li>• 2x4 kg portable fire extinguisher</li> <li>• 2 pcs Wheel chocks</li> <li>• Front and rear towbar</li> <li>• Back-up alarm and light</li> <li>• Battery Isolator switch</li> </ul>	
<b>ANFO TANK</b>	
<b>ANFO Tank Capacity:</b>	2 x 500 l
<b>Charging Capacity:</b>	60 – 120 kg/min
<b>Charging Outlet:</b>	1 ¼"
<b>Air Requirement:</b>	4 – 6 m <sup>3</sup> /min at 6 – 7 bar
<b>ANFO Tank Type:</b>	Stainless steel
<b>ANFO Hose:</b>	Antistatic, 30/38 mm diameter
<b>ANFO Hose Total Length:</b>	50 m
<b>Flow Control Valves:</b>	Manual ball valve
Remote control actuator valve	
Hose cleaning valve	

#### EXPLOSIVE STORAGE BOX

- 2 pcs Antistatic storage box for caps and primary explosives

#### HOSE FEEDER

- 2 pcs Hydraulically driven ANFO hose feeder. One on board, one on manipulator
- Hydraulically driven winder and unwinder
- Hydraulically proportional hose feed speed
- Remote controlled hose speed between 5 – 20 m/min

#### ANFO CHARGING HOSE REEL

- Proportional, hydraulically driven
- 60 m ANFO charging hose reel

#### ELECTRIC CABLE

<b>Drive:</b>	Hydraulic
<b>Power:</b>	400 V – 50 Hz
<b>Cable:</b>	3 x 25 mm <sup>2</sup> + 15 mm <sup>2</sup>

#### MANIPULATOR

<b>Max. Reach Vertical:</b>	9.6 m
<b>Max. Reach Horizontal:</b>	6.8 m

#### CABLE REMOTE CONTROL

##### Specifications:

- All manipulator movements
- Hose feed
- Hose winder
- Proportional hose feeding speed
- ANFO charge on/off
- Hose length indicator
- Emergency stop
- Horn

#### OTHER

- Centralized greasing system

#### OPTIONS

- Automatic centralized lubrication system
- Air-conditioner (Heating and Cooling) in the cabin
- Manual activated fire extinguishing system
- Automatic and manual activated fire extinguishing system (Linear wired)
- Caliper brake system
- 2<sup>nd</sup> seat in the cabin
- 12 V emergency steering
- Diesel particulate filter - DPF
- EU Stage 5 diesel engine
- Rear view camera and LCD monitor in operator cabin
- Additional side view camera
- Spare wheel